

The Johnson County Highway Department is requesting bids for (1)one Kenworth K3 Series Medium Duty Truck (See Specifications). The truck is to be delivered to:

Bergkamp Incorporated  
3040 Emulsion Dr.  
Salina Ks. 67401  
C/O Dave Anderson

# Vehicle Summary

	<b>Unit</b>	<b>Chassis</b>	
Model:	K3 Series Medium Duty COE	Fr Axle Load (lbs):	12000
Type:	FULL TRUCK	Rr Axle Load (lbs)	21000
Description:	New Pres141117	G.C.W. (lbs):	33000
	<b>Application</b>	Road Conditions:	
Intended Serv.:	Construction. Vehicles used in the construction	Class A (Highway)	90
Commodity:	Asphalt	Class B (Hwy/Mtn)	10
	<b>Body</b>	Class C (Off-Hwy)	00
Type:	Volumetric mixer	Class D (Off-Road)	00
Length (ft):	16.0	Maximum Grade:	6
Height (ft):	13.5	Wheelbase (in):	146
Max Laden Weight (lbs):	5000	Overhang (in):	72
	<b>Trailer</b>	Fr Axle to BOC (in):	11
No. of Trailer Axles:		Cab to Axle (in):	135
Type:		Cab to EOF (in):	207
Length (ft):		Overall Comb. Length (in):	0
Height (ft):			
Kingpin Inset (in):			
Corner Radius (in):			
		<b>Special Req.</b>	
		U.S. Domestic Registry, 50-State	
	<b>Restrictions</b>		
Length (ft):			
Width (in):			
Height (ft):			

Model	Description	9,850
	<b>K3 Series Medium Duty COE</b>	0
	<b>K370 Class 7 Medium Duty COE</b>	0
	<b>LFNA, EURO 6, LHD, HI-HP, US REGISTRY</b>	0
	<b>CARB Idle Emissions Reduction Feature for PX-7 and PX-9</b>	0
	<b>Medium-duty 4x2 automatic.</b>	0
	<b>Asphalt</b>	0
	<b>Construction. Vehicles used in the construction industry, other than those listed above. Use typically involves operating on the jobsite, to pick up or deliver construction materials, or to position the vehicle for its intended use at the construction site. Includes such activities as delivery of precast concrete, concrete pumpers, flatbeds or roll-offs for delivery of construction materials or equipment, etc. Typically includes some operation off of paved roads. Road usage: any combination, which includes some Class C.</b>	0
	<b>Volumetric mixer</b>	0
	<b>U.S. Domestic Registry, 50-State</b>	0
<b>Engine &amp; Equipment</b>	<b>PACCAR PX-7 220 2013 220@2400 215@2600 520@1600.</b>	0
	Includes turbo exhaust brake, no code is used. Diagnostic Plug for data link, Oil Cooler, Aluminum Flywheel Housing.	
	N09020 P02 Yes..Cruise Control Auto Resume	
	N09040 P04 No...Auto Engine Brake in Cruise	
	N09060 P06 No...Gear Down Protection	
	N09100 P11 Yes..Engine Protection Shtdwn	
	N09120 P14 75...Max Vehicle Speed in Top Gear	
	N09140 P19 75...Max Cruise Control Speed	
	N09160 P26 1400.Max PTO Speed	
	N09180 P10 No...Idle Shtdwn	
	N09200 P32 5....Idle Shtdwn Time	
	N09220 P33 No...Idle Shtdwn Override	
	<b>Prospector version 35.0 Supersedes 34.0</b>	0
	<b>Air compressor: Cummins 18.7 CFM, Cummins, PACCAR PX engines.</b>	0
	<b>Air cleaner - Fender Mtd RH BOC</b>	0



Description	Weight
<b>Air Intake: High</b>	0
<b>Cooling Module</b>	0
<b>Horizontal crossover DPF/SCR w/</b> horizontal tailpipe below LH rail.	0
<b>Fuel filter PACCAR PX-7 engines</b> and Cummins ISB Euro 3 Unheated.	0
<b>Immersion Type Pre-Heater 110-120V</b>	0
<b>Alternator: Bosch 160 amp, brush type</b> only.	-6
<b>Batteries: 2 PACCAR GP31 threaded post (1000)</b> 2000 CCA starting.	0
<b>Starter: Delco 12V 29MT</b>	0
<b>Battery Disconnect Switch: 1 Battery box locking</b>	0
<b>Transmission &amp; Clutch</b>	0
<b>Transmission: Allison 2500RDS 5-speed</b> w/PTO drive gear. 5th Gen controls. Includes heat exchanger. Rugged Duty Series for vocational applications. Transynd transmission fluid is standard on all Allison 1000, 2000, 3000 & 4000 series transmissions.	0
<b>Driveline: 2 SPL100 1 centerbearing light duty.</b>	0
<b>Torque converter included w/Allison</b> Transmission.	0
<b>Delete Allison FuelSense</b>	0
<b>Front Axle &amp; Equipment</b>	0
<b>Dana Spicer E-1202I Front Axle rated 12K</b> 3-1/2in. drop.	0
<b>Front brakes included w/ front hub package.</b>	0
<b>12,000 lb. Air brake package; drum brakes,</b> iron 10-bolt hub piloted hubs.	0
<b>12,000 lb. front spring suspension with shock</b> absorbers	0
<b>12,000 lb. capacity single power steering gear</b>	0
<b>Rear Axle &amp; Equipment</b>	0
<b>Single Dana Spicer P22060S single reduction rear</b> axle. T300/K300: use with/air brakes. Single rear axle 22K capacity rated at 21K.	0
<b>Rear Axle Ratio - 5.29.</b>	0
<b>Single rear brakes included w/rear hub package.</b>	0
<b>21,000 lb. Air Brake Pkg includes 16.5x7 in.</b> brakes, cast drums, iron 10-Bolt hub pilot hubs, slack adjusters & oil seals for use with 22.5 wheels.	0

	Description	Weight
<b>Spring brakes</b>	<b>Wabco Electronic Brake System (EBS)</b> w/anti-lock system. 4S/4M *FR WHL+2 GRP RR WHL. K270/K370 only.	0 0
<b>Rear suspension: single Reyco 79KB taperleaf 21K.</b> Medium-duty. Unladen Height: 9 in. Laden Height: 7.5 in. Not rear air disc brake compatible.		0
<b>Tires &amp; Wheels</b>	<b>Front tires: Bridgestone R268ECOPIA 11R22.5 14PR.</b> 41.5 in. diameter, all position. F-side wall protector bar. 19.3 in. SLR. For P&D & construction vocations. Smartway certified.	0
<b>Rear tires: Bridgestone M710ECOPIA 11R22.5 14PR.</b> 41.8 in. diameter, drive. 19.5 in. SLR. Smartway certified. Code is priced per pair of tires.		0
<b>Rear Tire Quantity: 4</b>		0
<b>Front wheel: Accuride 50487 22.5x8.25 steel</b> Steel Armor[™] powder coat, hub pilot mount. 7400lb. maximum rating. 5-hand hole. Air disc brake compatible.		0
<b>Rear wheel: Accuride 50487 22.5x8.25 steel</b> Steel Armor[™] powder coat, hub pilot mount. 7400lb. maximum rating. 5-hand hole. Air disc brake compatible. Code is priced per pair of wheels.		0
<b>Powder coat white steel wheel. Use in conjunction</b> with front, dual front, rear, spare or lift axle wheel code(s). All wheels on chassis must have same finish color.		0
<b>Rear Wheel/Rim Quantity: 4</b>		0
<b>Frame &amp; Equipment</b>	<b>Frame Rail: 10-1/4 in. steel to 414 in.</b> The results of the engineering review may result in a change to the requested frame rail. If a change is required Kenworth Application Engineering will advise the dealer of the appropriate material specification for a substitute rail.	0
<b>146 inch wheelbase.</b>		0
<b>Bumper: Steel painted gray.</b>		0
<b>Steel space saver battery box, right hand back</b> of cab.		0
<b>Battery box location: RH Side.</b>		0
<b>Square End-of-Frame without crossmember.</b>		0
<b>Fuel Tanks &amp; Equip</b>	<b>Fuel Tank: 45 US gallon rectangular steel</b> BOC replace.	0



	Description	Weight
	<b>Rectangular DEF tank. 7.5 gallons of</b> useable volume. The tank will be located just forward of the under cab component on the side you specified, but will not be displayed in the Prospector graphic. Required capacity is calculated by fuel capacity of the vehicle and will accommodate two diesel re-fillings for every DEF re-filling.	0
	<b>DEF tank location is on the LH.</b>	0
	<b>Location: 45 gal fuel tank LH behind cab</b>	0
<b>Cab &amp; Equipment</b>		0
	<b>Steel Cab: BBC 63.4in Non-Slpr LHD With WABCO EBS</b> Steel 63.4 in. BBC, COE, LHD, with the following; Daycab rear window with tinted safety glass throughout, Electric windshield wipers with intermittent feature, Electric-Powered LH & RH window lifts with switch located on door pad, Heated driving mirrors LH and RH with convex mirror over RH door, High level grey interior trim, Rubber floor mats, Combo fresh air heater and air conditioner, Smartwheel - 18 in. black four-spoke soft touch steering wheel with adjustable tilt steering column, Electric horn, Cigar lighter (12V) with ash tray, Driver and Passenger seats, Console mounted push button transmission controls and backwall storage. Includes WABCO EBS.	0
	<b>Heater And Air Conditioner</b>	0
	<b>Dual Scale Speedometer MPH Over KPH</b> Includes: Speedometer with clock and outside air temperature display, Water Temperature Gauge, Fuel Level Gauge, Dual Air Pressure Gauges, DEF Level Gauge, and Visual & Audible System Warnings	0
	<b>Interior: Gray</b>	0
	<b>Drivers Seat: Sears C2 Air, High Back Fabric</b>	0
	<b>RD Seat 2 man bench Fabric</b> Not for use with center console w/storage and 2 cup holders	0
	<b>Kenworth Radio with AM/FM/WB/USB and Bluetooth</b>	0
	<b>Dual Heated and Motorized Mirrors. Includes 2</b> convex mirrors and 1 downward looking mirror on passenger side.	0
	<b>Rear Cab Stationary Window 17 in. x 36 in.</b>	0
<b>Lights &amp; Instruments</b>		0
	<b>Headlamps: Halogen Projector Low Beam, Halogen</b> Complex Reflector High Beam	0
	<b>Turn Signal</b>	0
	<b>External Lights - Fog / Driving Lights</b>	0
	<b>Combination Stop, Tail, Turn &amp; Backup Lights RH</b> & LH.	0
	<b>Daytime Running Lamps.</b>	0
	<b>Electric Backup Alarm: Meets SAE J994 &amp; OSHA</b> requirements.	0

	Description	Weight
<b>Air Equipment</b>	<b>Air Dryer: WABCO SS1200 Plus without Multi Port PPV</b>	0
<b>Extended Warranty</b>	<b>Medium-duty Warranty: 1-year/unlimited mi. Medium-duty Emissions Surcharge \$7000.</b>	0 0
<b>Miscellaneous</b>		0
<b>Paint</b>	<b>Paint color number. K270/K370 Paint Color M8870 Ice White Imron solid 1 color non-sleeper Spec A. Will be White L0006EB if no other color specified.</b>	0 0 0
<b>Total Weight</b>		<b>9844</b>

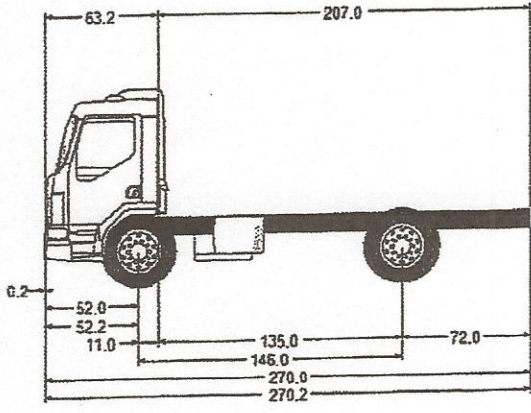



Steve Hake - MHC Kenworth in Salina, KS. 785-823-9700

[steve.hake@mhctruck.com](mailto:steve.hake@mhctruck.com)

Jason Mims - French-Ellison in San Antonio, TX 210-662-9333

[jason.mims@frenchellison.com](mailto:jason.mims@frenchellison.com)

Matt Killgore – MHC Kenworth in Kansas City, Mo. 816-841-2031

[matt.killgore@mhctruck.com](mailto:matt.killgore@mhctruck.com)

Matt Lore – Custom Truck in Kansas City, Mo. 816-210-3195